

DATASCOPE ABBREVIATED OPERATOR'S GUIDE
FOR THE *System* | 97 INTRA-AORTIC BALLOON PUMP

System | 97

INITIAL SET-UP

- 1 Establish power and verify MAINS POWER SWITCH - On
- 2 Open Helium tank and verify Helium pressure
- 3 Establish ECG and pressure connections from the patient
- 4 Zero transducer
- 5a Confirm initial pump settings:
 - ECG Trigger
 - IAB Frequency 1:1
 - IAB Augmentation: Off
 - IAB Inflation:] ▼ MidPoint
 - IAB Deflation:]
- 5b Confirm Auxiliary/Override Controls:
 - Slow Gas Loss Alarm - On
 - IAB Fill - Auto
 - Timing - Auto
 - ECG Gain - Normal
- 6 Set initial timing:

Position INFLATION and DEFLATION slide controls so that the intensified portion of the arterial pressure waveform occurs during diastole
- 7 Fill IAB catheter:

Connect IAB catheter and appropriate extender to the safety disk.
Press IAB FILL - hold for 1 second until "Autofilling" message appears
- 8 Initiate pumping:

Press ASSIST/STANDBY
Increase IAB AUGMENTATION to MAX
Verify AUGMENTATION ALARM set

The System 97 provides comprehensive HELP SCREENS with easy to follow step by step instructions on set-up as well as all alarm and alert conditions.



Note: This guide is a reference for personnel trained in using the Datascope System 97. Complete instructions for operation are provided in the Datascope Operating Instructions: System 97 Manual (0070-00-0262). Do not use this guide until thoroughly reading the Operating Instructions.

Datascope[®]

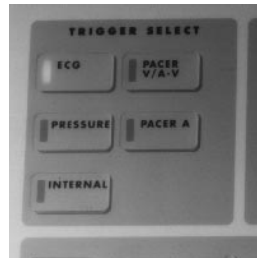

TRIGGER

Trigger is the signal the System 97 uses to identify the beginning of the cardiac cycle. There are five different trigger selections available.

1 ECG: The R wave of the ECG is the trigger event. Pacer rejection is automatic provided the pacer spikes are enhanced on the System 97 screen. ESIS (electrosurgical interference suppression) is automatic in this mode.

When the ECG trigger mode is selected, the ECG gain can be varied using the VARIABLE keys located behind the AUXILIARY CONTROLS door. The ECG gain can be varied from 0.15 to 3.00, relative to a normal gain of 1.0. VAR x— will be displayed in place of ECG SIZE on the monitor screen when variable ECG gain is used.

Note: ECG is the preferred trigger mode

2 PRESSURE: The arterial pressure waveform is the trigger event. In normal operation, a 15 mmHg upstroke of the arterial pressure waveform is required to trigger the IABP. Balloon deflation must be positioned before the upstroke of systole. If a trigger is missed in the assist mode, the pump will go to standby and examine the next few trigger events before resuming assistance.

When the pressure trigger mode is selected, the pressure trigger threshold can be varied from 7-30 mmHg using the VARIABLE keys located behind the AUXILIARY CONTROLS door. The pressure trigger threshold is displayed with the trigger source on the monitor screen. The arterial waveform is marked to indicate the trigger point.

Note: Pressure triggering is NOT recommended for use with irregular rhythms. Readjustment of timing may be necessary if pressure trigger threshold is changed. Avoid late deflation.

3 INTERNAL: The trigger is an internal signal generator allowing asynchronous assistance. In normal operation, the rate is fixed at 80 BPM. When the internal trigger mode is selected, the internal trigger rate can be adjusted from 40 to 120 BPM, in increments of 5 BPM, using the VARIABLE keys located behind the AUXILIARY CONTROLS door.

Note: Should the System 97 detect a valid QRS complex while in INTERNAL TRIGGER, automatic R wave deflation is activated and the message "ECG Detected" will be displayed on the monitor screen.

Warning: Never remain in the INTERNAL TRIGGER mode if the patient is generating a cardiac output.

4 PACER V/A-V: The ventricular spike of a ventricular or an atrial-ventricular pacemaker is the trigger event provided there is a 100% paced rhythm (no demand pacing). Pacemaker spikes must be ENHANCED for detection.

PACER V: Assists 100% ventricular paced rhythms up to a rate of 185 beats per minute.

PACER A-V: Assists 100% atrial-ventricular paced rhythms provided the A-V interval is between 80-225 msec. and the rate is less than 125 beats per minute.

5 PACER A: The R-wave of the ECG is the trigger event. Atrial pacer spikes are enhanced and rejected. Atrial pacemaker pulse rejection time is expanded in this mode allowing for rejection of large atrial pacer tails.

Note: Use only if atrial pacer spikes are interfering with R wave detection in the ECG trigger mode. Never use Pacer A trigger in the presence of a ventricular paced rhythm.

TIMING

Timing refers to the positioning of inflation and deflation points on the arterial pressure waveform. Inflation occurs at the onset of diastole and deflation occurs prior to ventricular ejection. On the monitor screen, with the pump in stand by, the highlighted portion of the arterial pressure waveform identifies the selected period of balloon inflation.

Optimal timing is illustrated below:



AUTO TIMING

With initial set-up, the operator selects the desired inflation and deflation points while in stand by, utilizing the highlighted portion of the arterial pressure waveform. After initiating assist, the IAB INFLATION and IAB DEFLATION controls can be adjusted to maximize augmentation and hemodynamic unloading. The System 97 will automatically adjust timing to accommodate changes in the patient's heart rate and rhythm.

MANUAL TIMING

In manual timing, the operator sets fixed inflation and deflation points as a function of time relative to the trigger point. If the heart rate varies by more than 10 BPM, readjustment of timing may be required.

In both AUTO and MANUAL timing, it is possible to view the inflation period while assisting, by pressing and holding the VERIFY key. The highlighted portion indicates the period of balloon inflation.



SYSTEM ALARMS, ALERTS, AND STATUS/PROMPTS

The System 97 provides the operator with comprehensive HELP SCREENS for all of the alarms and alerts. In the presence of an alarm or alert message, the operator can utilize the HELP SCREENS by pressing the HELP key on the control panel. The operator will be provided with step by step troubleshooting instructions. Detailed information on all alarms, alerts, and status/prompts is provided in the System 97 Operating Instructions.

ALARMS

ALARM messages are displayed in the ALARM MESSAGES section of the monitor display. IABP assist is suspended and a steady tone is sounded.

Trigger Alarms

These alarms indicate the selected trigger source is either not available or not reliable. Pumping is suspended and a steady tone sounds. Pumping will automatically resume once the trigger has been reestablished.

MESSAGE	CAUSE
No Trigger	Valid trigger does not exist
No Pressure Trigger	Valid trigger does not exist while in Pressure Trigger
No Pressure Trigger-Zero Transducer	Pressure Trigger is selected but the transducer has not been zeroed
Trigger Interference	Electrosurgical interference while in Pacer Trigger
Check Pacer Timing	V/A-V Pacer Trigger requirements have not been met

OPERATOR INTERVENTION

Assess the selected trigger and associated trigger criteria. If necessary, change trigger selection and resume pumping by pressing the ASSIST/STANDBY key.

Catheter Alarms

The System 97 continually monitors specific parameters within the closed patient pneumatic system. If a change is detected or a specific parameter is violated, IABP assist is suspended and a continuous tone is sounded.

MESSAGE	CAUSE
Leak in IAB Circuit	Small gas loss, gas gain, or slow leak in the IAB catheter circuit
Rapid Gas Loss	Large leak in IAB catheter or extender
IAB Disconnected	IAB catheter or extension tubing disconnected
Check IAB Catheter	IAB catheter kinked or balloon not fully unwrapped
Blood Detected	Blood has migrated into the drain tubing due to a leak in the IAB
Autofill Failure No Helium	IAB could not be adequately filled due to an inadequate supply of Helium
Autofill Failure	IAB could not be automatically filled but Helium supply is adequate
Autofill Required	The System 97 has been switched from manual fill to autofill or pump was placed in standby during the two hour scheduled autofill

OPERATOR INTERVENTION

Inspect the IAB and extender tubing for any evidence of a leak, including the safety disk/condensate removal assembly connections, IAB catheter connections, autofill tubing and drain port. Verify all connections are leak free. Open or replace Helium tank if necessary. Inspect the IAB catheter and extender for evidence of a kink or restriction to Helium flow. Fill the IAB, if instructed, by pressing the AUTOFILL key. Resume pumping by pressing ASSIST/STANDBY.

Warning: If blood is observed within the catheter or extender tubing at any time during the IAB procedure, stop pumping and notify the physician immediately.

Warning: When the System is operated in MANUAL FILL, the IAB GAS LOSS and CATHETER Alarms are disabled. The message, "Gas Loss And Catheter Alarms Disabled" will be displayed in the Advisory section of the display. The IAB status bar will not be active.

Warning: Under certain heart rate and timing conditions, catheter alarms may be suspended. Refer to Page 3-19 in the Operating Instructions for further detail.

Pneumatic Alarms

Pressure and vacuum are monitored internally within the system. When the parameters are violated, pumping is suspended and an audible alarm sounds.

MESSAGE	CAUSE
High Drive Pressure	Regulated drive pressure exceeds acceptable level
Low Vacuum	Insufficient compressor vacuum

OPERATOR INTERVENTION

Press the ASSIST/STANDBY key to resume pumping. If "Low Vacuum" persists and the patient is tachycardiac, change IAB FREQUENCY to 1:2. Pumping suspended due to a Low Vacuum alarm will resume automatically when vacuum is restored. If either alarm condition persists, contact Datascope service.

System Surveillance Alarms

The System 97 provides internal surveillance of certain parameters within the console.

MESSAGE	CAUSE
Electrical Test Fails Code # _____	Electrical failure during power-up diagnostics
System Failure	Microprocessor or other electronic/pneumatic failure
Safety Disk Test Fails	Leak in safety disk/condensate removal assembly or pneumatic fitting during a safety disk leak test

OPERATOR INTERVENTION

Refer to HELP SCREENS and/or the operating instructions.

ALERTS

ALERT messages are displayed in the ADVISORY section of the screen. IAB pumping is not suspended with alert conditions. A continuous ALERT message and double beep tone signals the operator that immediate corrective action is required. ALERT conditions that do not require immediate intervention will result in a double beep that repeats for 30 seconds. The ALERT message remains displayed until the alert condition is corrected.

MESSAGE	CAUSE
Augmentation Below Limit Set	Diastolic Augmentation has dropped below limit set
Irregular Trigger	Pressure Trigger in the presence of irregular rhythms or with deflation set too late
Heart Rate Low	Heart Rate <40 BPM
Low Helium	Helium supply is below 24-fill reserve
Low Battery	Battery time is below 30 minutes of operating time
Low Battery (EXT)	External battery time is below 30 minutes of operating time
ECG Detected	ECG activity exists while in Internal Trigger
Maintenance Required Code # _____	System maintenance may be required
No Patient Status Available	Software communications failure

STATUS/PROMPTS

STATUS/PROMPT messages are displayed in the ADVISORY section of the display. STATUS/PROMPT messages do not sound any tones (with the exception of “Unplug Disk Outlet” & “Plug Disk Outlet”) and are advisory in nature.

STATUS MESSAGE	CAUSE
System Trainer	Indicates Series 90 Trainer in use
System Test O.K.	Power-up diagnostics tests pass
Autofilling	Notifies the operator the system is automatically purging and refilling the IAB
Leak Testing Safety Disk	Indicates safety disk leak test is in progress
Slow Gas Loss Override On	Operator has disabled the slow gas loss alarm
Gas Loss and Catheter Alarms Disabled	Operator has selected the manual fill mode
Auxiliary Controls Unavailable	Auxiliary and recorder controls are not functioning properly
Battery in Use	Internal battery is being used
Battery in Use (EXT)	External battery or DC power source is being used

PROMPT MESSAGE	CAUSE
IAB Not Filled	IAB has not been filled
Unplug Disk Outlet	Instruction given at the start of a safety disk leak test
Plug Disk Outlet	Instruction given during safety disk leak test
Manual Fill IAB	Displayed during the manual fill process

[Help] Available for Initial Set Up	Displayed on bottom of monitor at power-up until first pumping cycle
[Help] Available for Manual Fill	Displayed on bottom of screen when user selects manual fill

Override/Auxiliary Controls

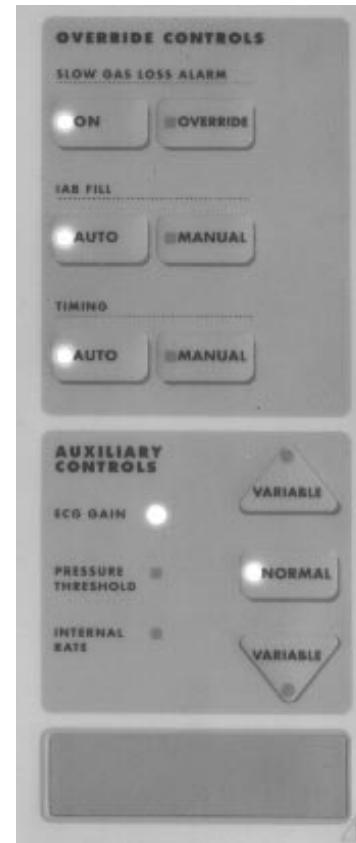

CLINICAL CONSIDERATIONS, ROUTINE CHECKS, PORTABLE OPERATION

CLINICAL CONSIDERATIONS

ECG

There are several methods to correct conditions which alter or hamper the acquisition of a reliable ECG. Repositioning electrodes to the anterior thoracic chest or replacement of the ECG electrodes, checking that the patient cable is properly connected, choosing an alternate lead selection and manipulating the ECG Gain setting are the most common solutions. If the ECG signal is acquired indirectly from a bedside monitor, ensure the appropriate cable is utilized and the bedside monitor is in the diagnostic output mode.

Arrhythmias

ATRIAL FIBRILLATION

Use AUTO TIMING and ECG TRIGGER.

IAB INFLATION/DEFLATION should be adjusted to position the intensified portion of the arterial waveform to correspond with diastole. Moving the DEFLATE slide to the extreme right will result in automatic R wave deflation. Adjust the augmentation alarm limit using the AUG ALARM key and the UP and DOWN arrow keys to accommodate the change in the patient's pressure.

ECTOPICS

The System 97 automatically deflates and provides assist when the ectopic is sensed. To ensure reliable triggering with ectopics, select the lead that minimizes the amplitude differences between the normal QRS and the ectopic. If the arterial pressure decreases during the ectopic beat, the augmented diastolic pressure may also be decreased.

Cardiac Arrest/Defibrillation

If possible, use ECG or PRESSURE Trigger during CPR. The system will synchronize trigger to the rate and rhythm of chest compressions. If ECG or ARTERIAL PRESSURE Trigger can not be utilized, INTERNAL Trigger may be utilized to allow balloon movement. When defibrillating, the System 97 is completely isolated from the patient, however, the operator should stand clear of the System during defibrillation.

Note: The IAB should not remain immobile for more than 30 minutes in situ.

CHANGE IN PRESSURE MONITORING SITE

If the arterial pressure monitoring site is changed while pumping, quickly press and release the VERIFY key to recalculate arterial pressure transmission delay. This will ensure accurate digital pressure displays and arterial pressure trace intensification.

SAFETY DISK LEAK TEST

The safety disk should be removed from the condensate removal module and replaced after 1000 hours of use or 2 years, whichever comes first. The safety disk should also be checked on a regular basis. To initiate the safety disk leak test, the following procedure should be performed:

- 1 Press and hold the IAB FILL key while turning on the power. Release the IAB FILL key when the message “Safety Disk Leak Test” appears adjacent to the ADVISORY section of the screen.
- 2 After approximately 10 seconds, a tone sounds and the message “Plug Disk Outlet” will be displayed adjacent to the ADVISORY section.
- 3 Plug the IAB CATHETER EXTENDER INPUT with a luer lock plug or a closed stopcock.
- 4 The System 97 will proceed with the test which takes approximately 6 minutes.

When the test is complete, a 10 second tone will sound and the message “System Test O.K.” or “Safety Disk Test Fails” is displayed adjacent to the ADVISORY section. If the safety disk leak test fails, check all pneumatic connections. Turn the pump OFF and repeat from Step 1. If the safety disk leak test fails again, replace the safety disk.

Warning: This procedure must not be performed when the system is connected to the patient.

PC-IABP REMOTE MODEM DIAGNOSTICS

The System 97 is equipped with a telephone jack located on the rear panel below the helium tank. When a direct dial analog telephone line is connected from the telephone jack in the wall to the telephone jack in the IABP, patient data, waveforms, and pump information can be accessed from a remote location using a computer and the PC-IABP software.

TO USE THE MODEM CAPABILITIES OF THE SYSTEM 97:

Connect a telephone cord from the telephone jack in the wall to the “Telecomm Output” port located on the rear panel of the System 97 below the helium tank.

From a separate telephone line, contact the person who is going to connect by computer with the IABP and provide them with the phone number of the telephone line connected to the IABP.

They can now connect with the IABP to view waveforms, patient data, and pump information.

STRIP CHART RECORDER

The dual trace recorder provides a hard copy record of patient ECG, arterial pressure, trend data or balloon pressure waveform (optional). Alarm/Advisory messages, Timing and Trigger mode, heart rate and key pressures are provided at the end of the strip. Trigger event markers are annotated across the top of the strip with inflation/deflation markers at the bottom of the strip.

To activate the recorder, press one of the tracing controls. If a dual trace is desired, press the second control within 1.5 seconds. To end the recording, press the OFF control.



DOPPLER

The System 97 is equipped with a doppler located in the upper storage compartment on the side of the System 97 cart.

To Use:

- 1 After removing the doppler from the storage compartment, press the on/off key located on the front of the doppler. The LCD will display the power ON indicator.
- 2 Place a small amount of coupling gel on the doppler probe or at the site to be examined.
- 3 Place the probe at a 45 degree angle over the artery to be assessed.
- 4 Listen for pulsatile blood flow sounds, adjust volume control as needed.

If battery replacement is necessary, remove the cover of the battery compartment, and lift out the old battery. Install a new 6LR61, 6LF22, or equivalent 9V alkaline battery. Slide the cover back into position.

TRANSPORT CONSIDERATIONS

The System 97 has an automatic sleep mode feature. If it is necessary to disconnect patient connections or to detach the battery from the console to facilitate movement into a transport vehicle or aircraft, the System 97 will hold the settings in memory for 15 minutes. Once the patient and pump are reattached, turn the power ON, verify timing settings, and initiate an Autofill. Press ASSIST/STANDBY to resume pumping.

PORTABLE OPERATION

PORTABLE OPERATION FROM INTERNAL BATTERIES:

To switch from AC power to battery operation, unplug the power cord from the AC outlet. The System 97 switches automatically to portable operation. The batteries recharge whenever the System 97 is plugged into an AC outlet with the MAINS switch ON. To maintain batteries at full charge and maximize battery life, it is recommended that the System be plugged in at all times even when not in use.

The message, "Battery In Use," will be displayed in the ADVISORY section of the monitor whenever the System 97 is operated from the internal batteries. When approximately 30 minutes of battery operation time remains, the following occurs: The message, "Low Battery," is continuously displayed in the ADVISORY section and a double beep alarm is activated for 30 seconds.

To return to AC power, plug the AC power cord into an AC outlet. The System automatically switches to AC operation and the internal batteries will recharge.

Verify BATTERY CHARGING indicator is illuminated when the system is plugged in.

If the unit is stored for an extended period and AC power is unavailable, disconnect the system battery pack from the console. Refer to the operating instructions for additional detail.

PORTABLE OPERATION FROM VEHICLE INVERTER:

The AC power for the System 97 can be supplied from an emergency vehicle inverter. The inverter should be checked for proper operation. Refer to section 3.9.3 in the operating instructions for vehicle inverter specifications. Interruption of the vehicle inverter AC power will result in portable internal battery operation.

PORTABLE OPERATION-EXTERNAL DC SOURCE:

The System 97 can also be powered from a voltage compatible external 24 or 28 volt DC power source. The message, "Battery in Use (EXT)" will be displayed in the ADVISORY section of the monitor when the System 97 is operated from the external DC power source. Interruption of the external DC source will result in portable internal battery operation. Refer to section 3.9.4 in the operating instructions for additional detail.

ALTITUDE CHANGES DURING AIR TRANSPORT

In the auto fill mode, the system will automatically purge and fill the IAB when local atmospheric pressure decreases or increases by 25 or 50 mmHg respectively. These pressure changes occur approximately every 1,000 feet of rise or 2,000 feet of drop in altitude.

The auto fill mode should be used during air transport. If the auto fill mode cannot be used and the manual fill mode is required, a manual fill must be performed at the same intervals that an auto fill would occur.

REMOVING PUMP CONSOLE FROM THE CART

The console can be removed from the cart with or without the battery pack attached.

Push the handle swivel release down (*Fig. 1*) and turn the cart handle counter-clockwise.

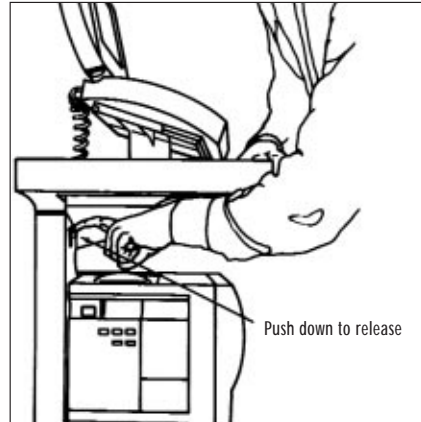

Fig. 1

To remove the console with the battery pack attached:

Unlock the console by pressing the tab to the right of the console release handle and pull the handle straight out (*Fig. 2*).

Lift the pump console straight up and off the cart.

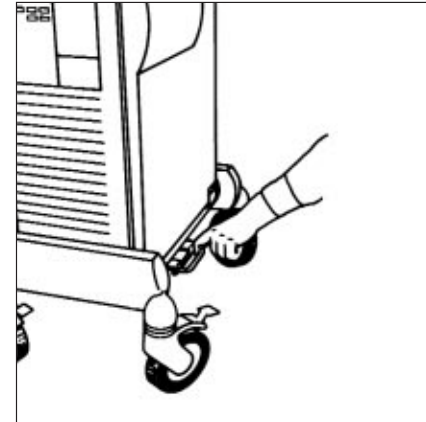

Fig. 2

To remove the console by detaching the battery pack:

With the console on the cart, lift the battery release levers to the unlock position (*Fig. 3*). Lift the console straight up and off the cart (*Fig. 4*). To release the battery from the cart, unlock the battery pack by pressing the tab to the right of the console release handle and pull the release handle straight out. Lift the battery pack off the cart. With the release levers in the unlocked position, lift the pump console and lower it straight down onto the battery pack. Return the release levers to the locked position.

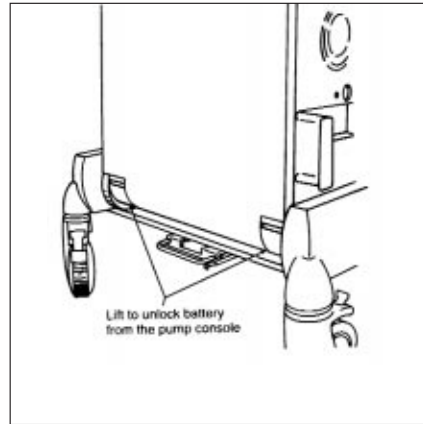

Fig. 3

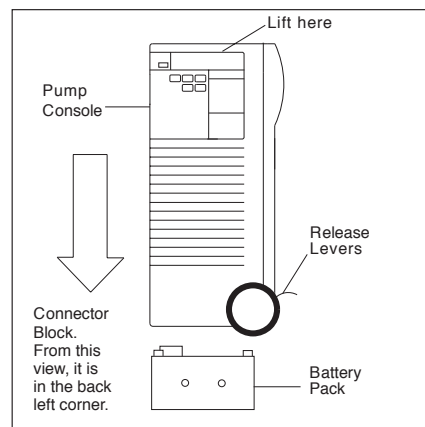

Fig. 4

To attach the monitor to the pump console:

Detach the monitor from the cart handle by pressing the button on the rear of the monitor (*Fig. 5*).

Attach the monitor to the top of the pump console. Extend the console handle. Make sure the monitor is securely attached before moving the system (*Fig. 6*).

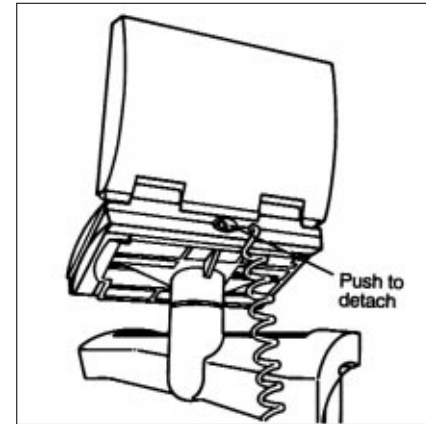

Fig. 5



Fig. 6

Datascope Corp.
Cardiac Assist Division
15 Law Drive
Fairfield, NJ 07004

For Emergency Assistance:
1-800-777-4222 (within the U.S.)
1-201-244-6100 (outside the U.S.)